



DAF XF / XG / XG+ 2021-

Art. 850340, 850341, 850362, 850363

Laternakandur TOP | Lamp holder TOP | Носител фар TOP | Scheinwerferbügel TOP



1. Laternakandur / lamp holder / носител фар / Scheinwerferbügel	1
2. Polditav kronstein / bolt bracket / кронштейн / Bolzenhalterung	2
3. Kronstein / bracket / кронштейн / Konsole	1
4. Kronstein / bracket / кронштейн / Konsole	1
5. Kronstein / bracket / кронштейн / Konsole	2
6. Laternaalus / lamp fixing bracket / крепежный кронштейн лампы / Lampenbefestigungsklammer	4
7. Liigend / ball joint / шарнир / Scharnier	2
8. Liigend / ball joint / шарнир / Scharnier	2
9. Kompensaator / compensator / компенсатор / Kompensator	2
10. Kummiseib / rubber washer / резиновая шайба / Gummisscheibe d=30/15	4
11. Magnetkinnitus / magnetic fastening / магнитное крепление / Magnetbefestigung d=66 M8x15	2
12. Polt / bolt / болт / Bolzen M8x20 DIN933-A2	4
13. Polt / bolt / болт / Bolzen M8x20 DIN7380-A2	4
14. Polt / bolt / болт / Bolzen M8x25	10
15. Mutter / nut / гайка / Mutter M8 DIN985-A2	6
16. Mutter / nut / гайка / Mutter M8 DIN439-A2	2
17. Tõmbemutter / rivet nut / тяговая гайка / Nietmutter M8x11x16	4
18. Seib / flat washer / шайба / Scheibe 8,4x16x1,6	20
19. Vedruseib / spring washer / пружинная шайба / Federnscheibe A8	14
20. Läbiviik / grommet / проходная подкладка / Tülle	1

M8 - 25 Nm

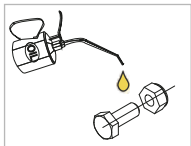

Kaal / Weight / Масса / Gewicht: 10,1 kg

Paigaldusaeg ilma elektritöödetä / Time of mounting w/o wiring works / Время установки без электромонт. работ / Einbauzeit ohne elektrische arbeit: 60 min

Vajalikud tööriistad / Required Tools / Необходимые инструменты / Benötigte Werkzeuge

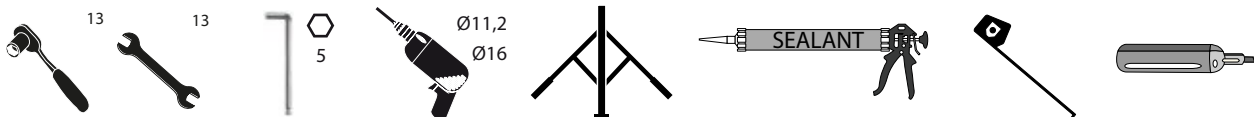

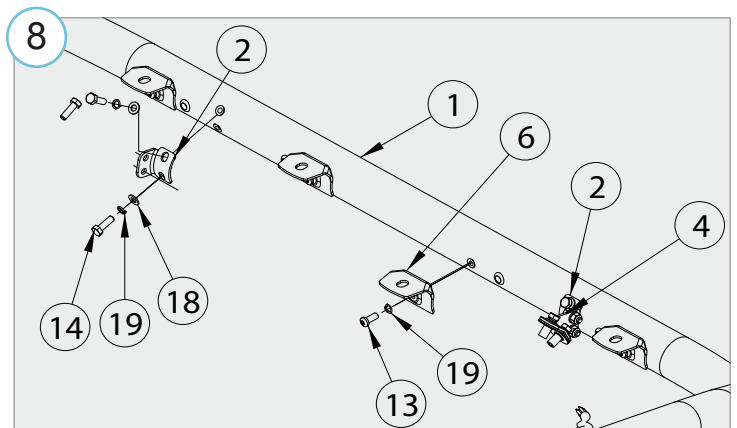
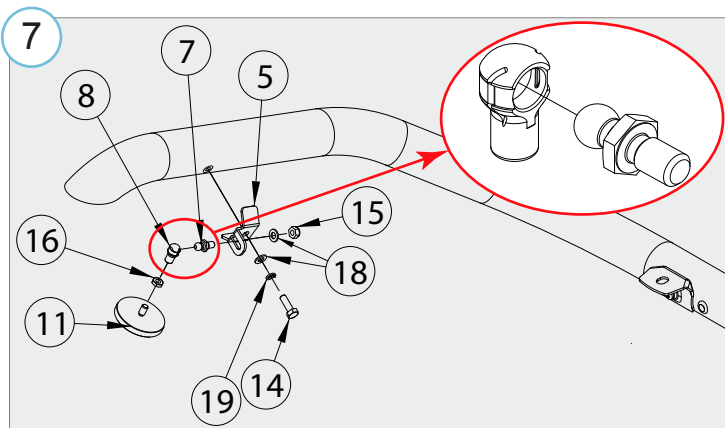
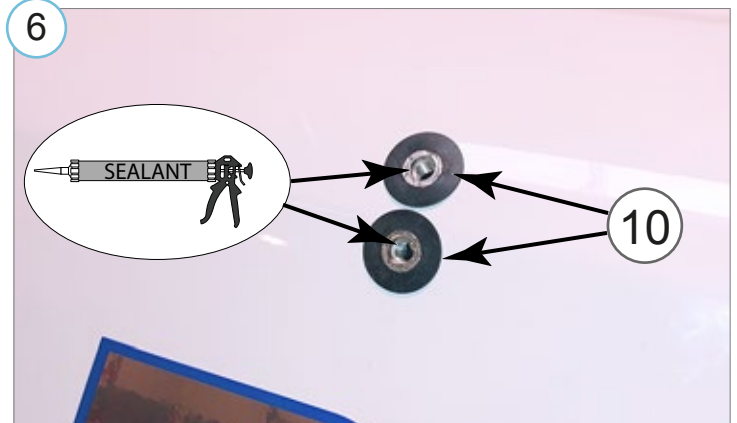
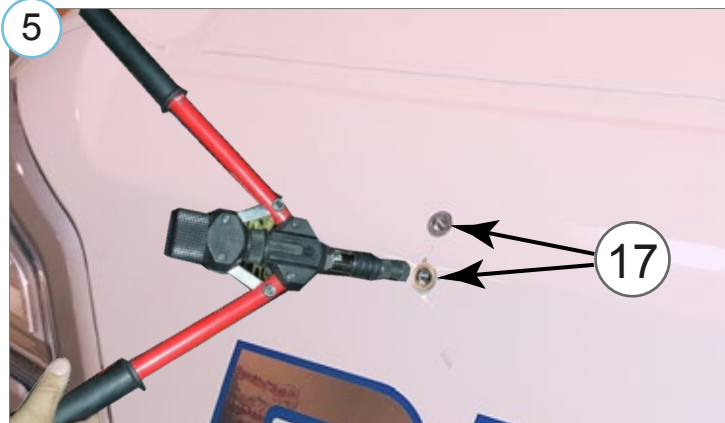
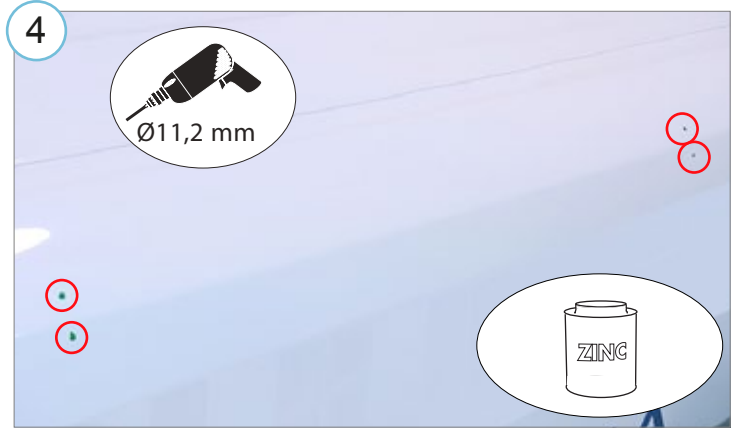
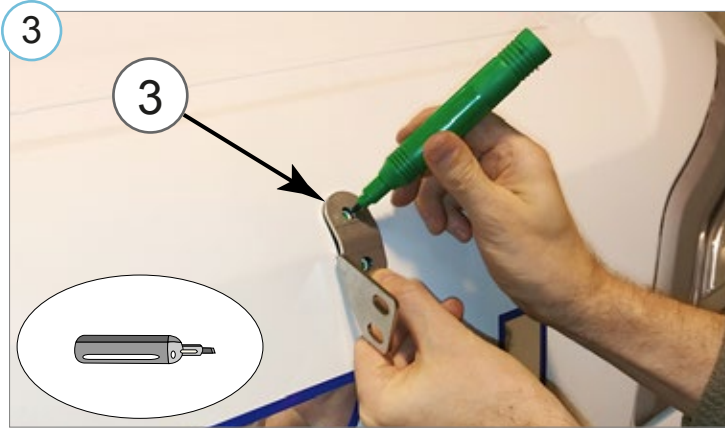
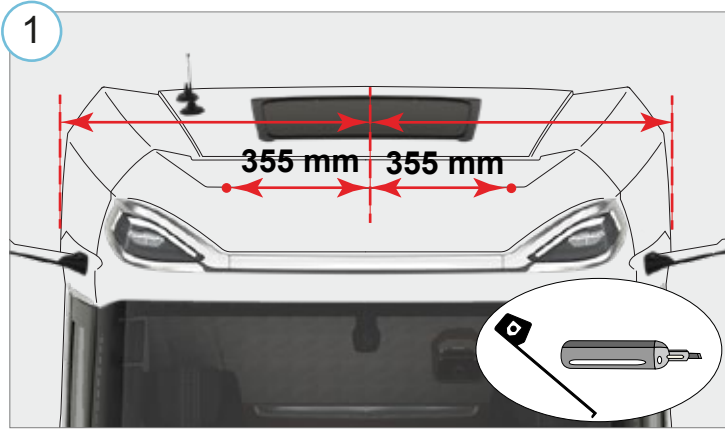

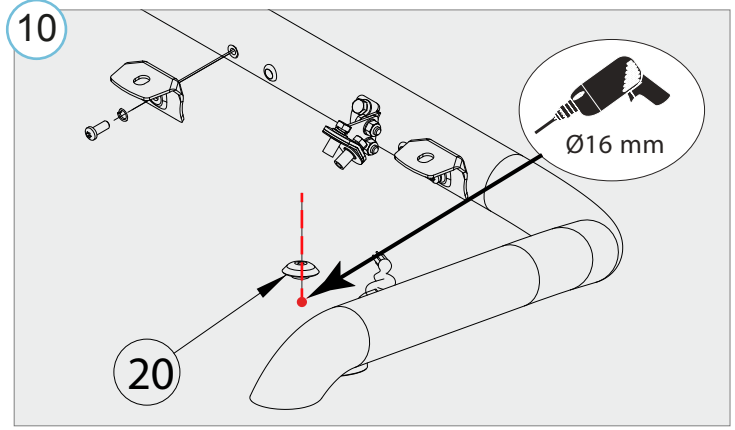
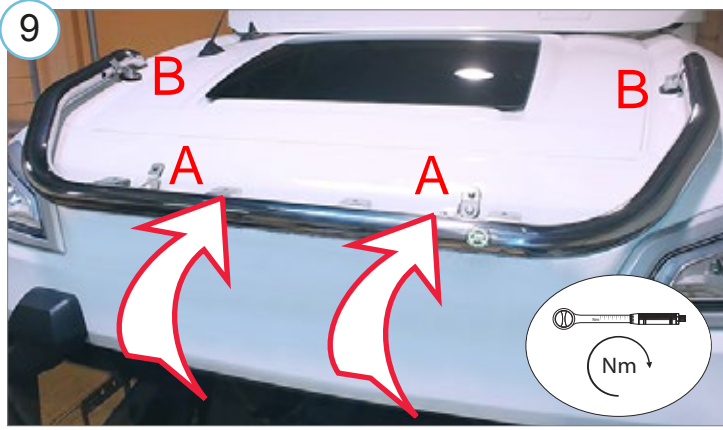

11

Elektriühendused teostada kvalifitseeritud autoelektriku poolt

Installation of the lights can be carried out by qualified electrician only

Монтаж огней может быть выполнено только квалифицированным электриком

Die Installation der Lichter können durchgeführt werden durch Elektrofachkraft

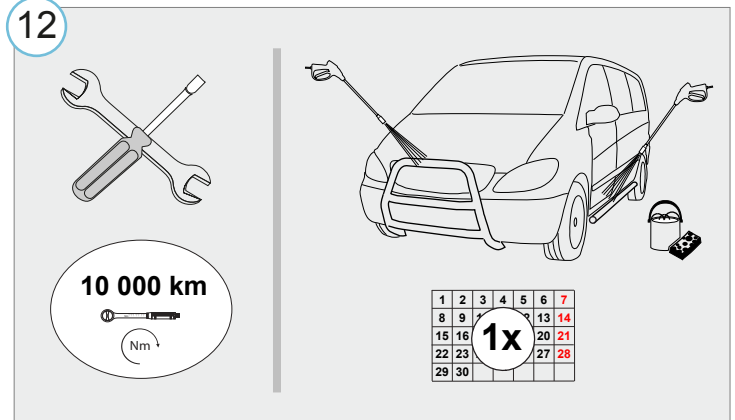

Switching pattern of the lights of the holder with 4 light connections. Led marker lights connected inside the tube. (if presented)

Juhul kui lampide A+B+C koguvõimsus ületab 280 W tuleb juhtmesarja võimalikke signaali juhtmeid (A/B) kasutada täiendavaks maanduseks! Erinevate laternate võimalik samaaegsete lülituste arv väheneb.

If the total wattage of the headlights A+B+C exceeds 280 W, the signal cables of the wiring harness (A/B) must be used as additional grounding! The number of possible simultaneous switching of different headlamps is decreasing.

Если общая мощность фар A+B+C превышает 280 Вт, сигнальные кабели жгута проводов (A/B) следует использовать в качестве дополнительного заземления! Количество возможных одновременных переключений различных фар уменьшается.

Falls die Gesamtleistung der Scheinwerfer A+B+C 280 W übersteigt, sind die eventuellen Signalkabel des Kabelbaums (A/B) als zusätzliche Erdung zu verwenden! Die Anzahl möglicher gleichzeitiger Schaltungen verschiedener Scheinwerfer verringert sich.

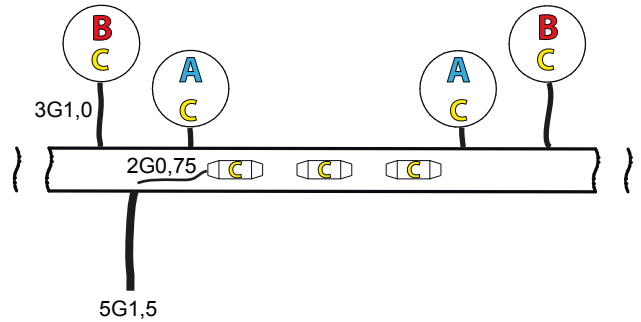

possible switch ON position	Harness ID number references / Juhtmesarjade viited			
	5G1,5	3G1,0 B	3G1,0 A	2G0,75
C+	1	1	1	2
A - C-	Gr/y	Gr/y		1
B+	2		2	
A+	3	2		
B-	4		Gr/y	

Lisa / extra / приложение / Extra

